

## LB Foundation anchor

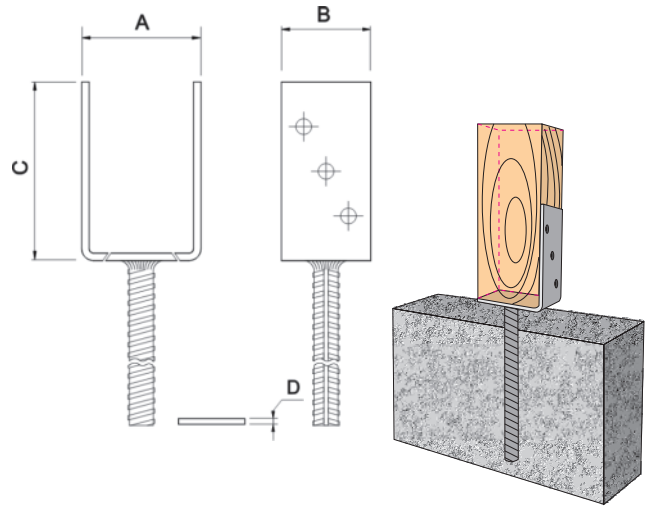

AT-15-8508/2012



### Description

Plate fastener for timber-to-concrete connections.

Material: steel sheet. Corrosion protection: zinc plated. Fire resistance class A1

Code	Dimensions [mm]				No. of holes ø10.5	Design resistance [kN]	Pcs 
	A	B	C	D			
LB-01(X10)	70	60	125	5	6	1.86	10
LB-02(X10)	80	60	125	5	6	1.86	10
LB-03(X10)	90	60	125	5	6	1.86	10
LB-04(X10)	100	60	125	5	6	1.86	10
LB-05(X10)	150	60	125	5	6	1.86	10
LB-07(X10)	120	60	125	5	6	1.86	10
LB-08(X10)	140	60	125	5	6	1.86	10
LB-06-OT(X10)	84	90	135	5	6	1.86	10

## LB-9 Adjustable foundation connector



AT-15-8508/2012

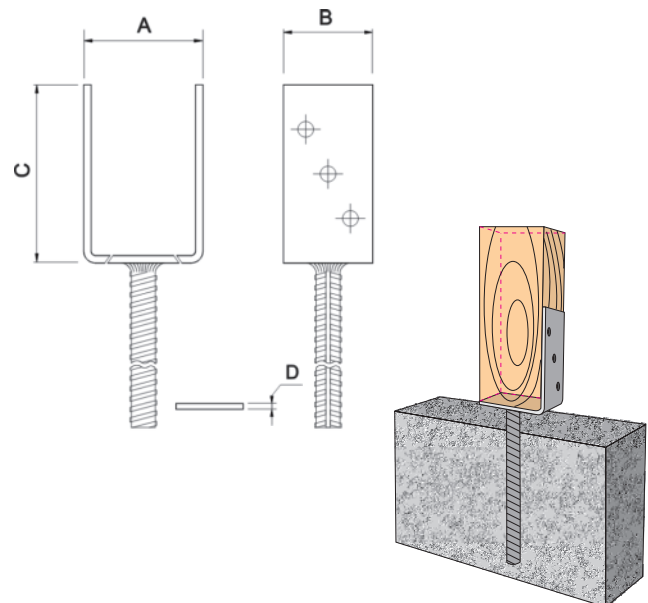

### Description

Plate fastener for timber-to-concrete connections.

Material: steel sheet. Corrosion protection: zinc plated. Fire resistance class A1

Code	Dimensions [mm]				No. of holes ø10.5	Pcs 
	A	B	C	D		
LB-9(X10)	80-170	60	90	5	10	10